

# Essence

## 6100851 BOILER APRON (Ordernumber: 6100851-0072)

Minimalistic and functional boiler apron with adjustable neck strap and waist ties to be tied at front or back depending on what look you want. Two integrated front pockets will hold all needed devises when serving and helping customers.

Fabrics made of upcycled materials and responsible production processes.

### COLOURS:



0072-Black

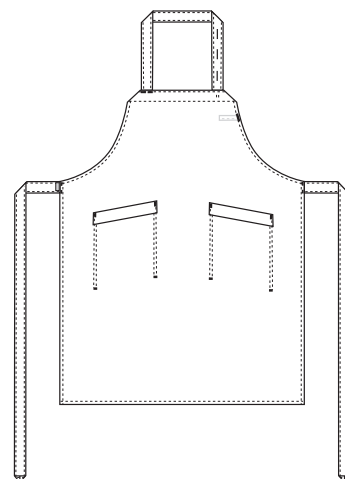

### FACTS:

- Neck strap with adjustable length
- Tighten with straps at hip
- Two integrated front pockts
- One size

**QUALITY:** 50/50% Lyocell Refibra/Recycled polyester – 235 g/m<sup>2</sup>

**STOCK SIZES:** One-size

**CERTIFICERING & OUR ICONS:**



www.oeko-tex.com



www.oeko-tex.com



### FINISHED MEASURES BEFORE WASHING:

One-size: 70 x 90,5 cm



Please note: Final measures will depend on tolerance in garment making (See above) and measuring method (+/- 0.5 cm)  
Also note: Washing and drying conditions in industrial laundering can further more give a shrinkage up to 3-5% (Depending of material)  
All models meet the requirements industrial laundry. Washing instructions on our homepage [www.nybo.com](http://www.nybo.com)

### DOMESTIC LAUNDERING:



PURVEYOR TO H. M. THE QUEEN OF DENMARK  
**NYBO**  
WORKWEAR SINCE 1962

